

2

1

NOTES :

- 1-MATERIALS:
  - HELIX PLATE PER CSA G40.21 50W, MIN.FY=60 KSI, ULTIMATE STRENGTH 70 KSI
  - TUBE PER ASTM A500 GR C, FY=60KSI, FU=70KSI
- 2-ANY CHANGE OF MATERIAL IS SUBJECT TO GOLIATHTECH APPROVAL
- 3-WELD PERFORMED IN ACCORDANCE WITH CSA STANDARD W47.1 AND GOLIATHTECH WELDING PROCEDURES. WELDERS ARE ALSO CERTIFIED TO THE AWS STANDARD.

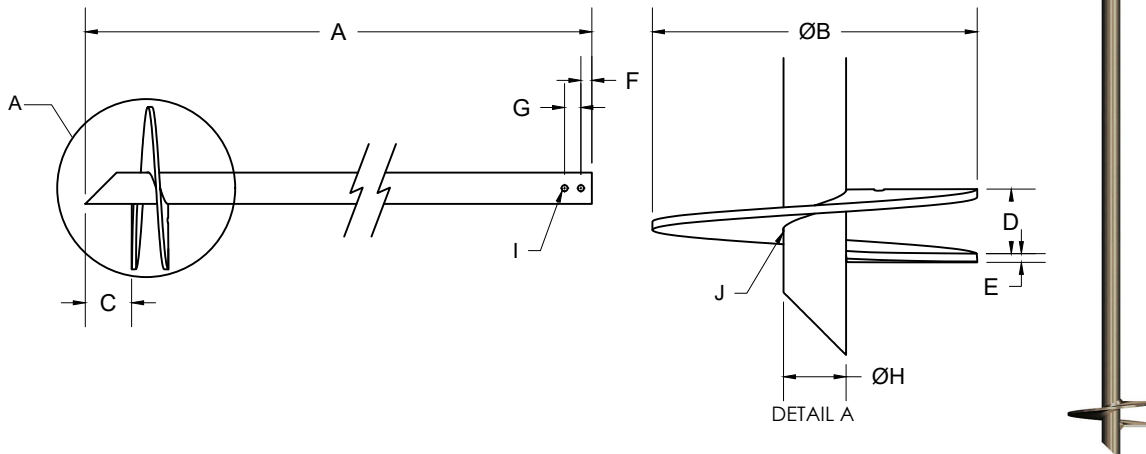

3		
2		
1	INITIAL RELEASE	2023-07-19
REV	MODIFICATION	DATE

MECHANICAL ASD LOAD CAPACITY

NO.	Dimension (inches)	Description	MECHANICAL ASD LOAD CAPACITY							
			Unbraced Shaft Length, Lu (ft)	Compression (kips)			Tension (kips)	Lateral (kips)	Bending Moment (kips.ft)	Max Soil Capacity Comp/Ten* (kips)
				0 Coupler	1 Coupler	2 Coupler				
A	54		0	26.3	26.3	26.3	11.74	6.40	1.51	15.75
B	9		5	9.7	5.2	3.1				
C	4 1/4		10	4.3	3.1	2.2				
D	PITCH 3		15	2.2	1.9	1.5				
E	3/8		20	1.4	1.2	1.1				
F	1		<b>Note:</b> 1. Soil capacity (P4) must be determined per Section 4.1.5 of this report. 2. Maximum ultimate soil capacity is determined from $P_{ult} = K_t \times T$ based on the corresponding maximum installation torque rating for the specific pile model. Allowable soil capacity is determined from $P_a = P_{ult} / 2.0$ based on the corresponding maximum installation torque rating for the specific pile model. See Section 4.1.5 for additional information. 3. Mechanical torsion rating is the maximum torsional resistance of the steel shaft. 4. Maximum Torque Per Soil Tests is the maximum torque achieved during field axial verification testing that was conducted to verify the pile axial capacity related to pile-soil interaction. 5. Maximum Installation Torque rating is the lower of the "mechanical torsion rating" and the "maximum torque per soil tests". 6. The allowable soil capacity under the IRC must be determined in accordance with Equation 3 of Section 4.1.5 of this report, when applicable. *7. Min required installation depth for tension is 12D where D is the diameter of the uppermost helix. 8. Max Soil Capacities based on the the tube torsional capacity.							
G	1 1/2									
H	2 3/8									
I	9/16									
J	1/4	Weld								



GOLIATHTECH VENTURA LINE

TITLE: 4.5 Foot Screw Pile of 2 3/8 (0.154 wall) with a 09" Helix

SEAL:	DWG. NO :	VGTP123809-4.5FT
	DRAWN BY:	R.E
	DESIGN BY:	GOLIATHTECH
	CHECK BY:	CPOC
	APP BY:	CPOC
	OTHER NO :	-

FORMAT : A	REV.:	DATE :	PAGE :
SCALE : NTS	1	2023-07-19	1 DE 1

THIS DOCUMENT CONTAINS PROPRIETARY INFORMATION AND MAY NOT BE REPRODUCED OR COPIED WITHOUT THE EXPRESS WRITTEN PERMISSION OF A DULY AUTHORIZED REPRESENTATIVE OF GOLIATHTECH INC.

2

1