

2

1

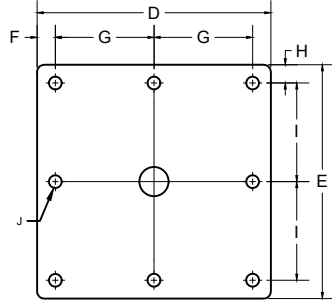
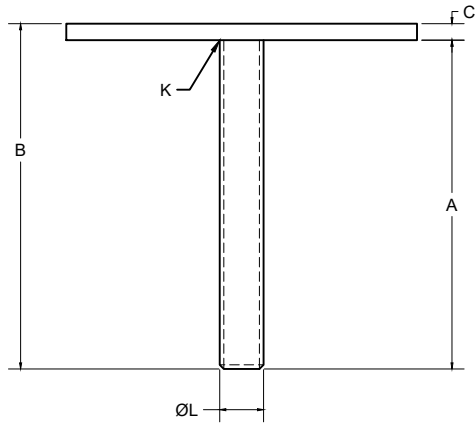

NOTES :

- 1-MATERIALS:
 -PLATE PER CSA G40.21 50W, MIN.FY=60 KSI, FU=70KSI
 -F3125 GRADE A325 OR ASTM A449 TYPE 1 WITH MIN.YIELD STRENGTH OF 92 KSI AND MIN.TENSILE STRENGTH OF 120 KSI.
- 2-ANY CHANGE OF MATERIAL IS SUBJECT TO GOLIATHTECH APPROVAL
- 3-WELD PERFORMED IN ACCORDANCE WITH CSA STANDARD W47.1 AND GOLIATHTECH WELDING PROCEDURES. WELDERS ARE ALSO CERTIFIED TO THE AWS STANDARD.

B

B

3		
2		
1	INITIAL RELEASE	2023-09-25
REV	MODIFICATION	DATE

MECHANICAL ASD LOAD CAPACITY

NO.	Dimension (inches)	Description	Compression (kips)		Tension (kips)	Lateral (kips)
			Deployment of Threaded Rod (inches)			
A	7 1/2		0	26.30	5.78	7.59
B	7 7/8		0.5	26.30		
C	3/8		1	26.30		
D	8		2	26.30		
E	8		3	24.71		
F	5/8		4	22.75		
G	3 3/8		5	21.01		
H	5/8		6	19.45		
I	3 3/8		Max	18.17		
J	7/16					
K	1/4	Weld				
L	1 - 8 UNC					

Note:
 1.The ASD capacities are based on limit states associated with mechanical steel strength of the bracket to the helical pile shaft. Steel column, shaft, or geotechnical capacities may control. The member supported by the bracket must be designed by the registered design professional and must not exceed the tabulated capacities. The supported member must be connected to bracket plate with a minimum of four bolts ASTM A325 and must have a minimum thickness of at least 1.5 times the plate thickness.
 2.The tabulated capacities assume the pile foundation system is sideway braced per IBC Section 18.10.2.2
 3.Tabulated capacities based on four (4) - 1/2 - inch diameter hex head bolts
 4.Threaded rod length is the distance above the top of the adjustable connection head. Maximum threaded rod length is 6.507 inch.
 5.All components above the bracket, including the interaction between the base plate and the bolts, and the weld between base plate and its column, are to be determined by the design professional on a job specific basis.
 6.Capacities for bare steel brackets are based on bare steel losing 0.036-inch (318 µm) steel thickness as indicated in Section 3.9 of AC308 for a 50-year service life.
 6.Adjustable brackets are to be used with corresponding GTBASEXXX, see GTBASEXXX drawings for details.



GOLIATHTECH VENTURA LINE

TITLE: Flat 8x8" Plate 3/8 inch thick on 1" Threaded Rod

SEAL:	DWG. NO : VGTBRODPL8
	DRAWN BY: ARG
	DESIGN BY: GOLIATHTECH
	CHECK BY: CPOC
	APP BY: CPOC
OTHER NO : GTBASE238-8X8N-C-N	

FORMAT : A	REV.: 1	DATE : 2023-09-25	PAGE : 1 DE 1
------------	---------	-------------------	---------------

THIS DOCUMENT CONTAINS PROPRIETARY INFORMATION AND MAY NOT BE REPRODUCED OR COPIED WITHOUT THE EXPRESS WRITTEN PERMISSION OF A DULY AUTHORIZED REPRESENTATIVE OF GOLIATHTECH INC.

A

A

2

1