

HOUSES

# GOLIATH TECH

## SCREW PILE SYSTEM



## HELICAL PILE SUPPORT SYSTEM FOR HOUSES



ISO 9001:2015 CERTIFIED | ISO 14001:2015 ENVIRONMENTAL CERTIFIED | ICC-ES ESR-3726  
AWS D1.1 / CWB CERTIFIED | CCMC CERTIFIED #13675-R | ACQ & CA COMPLIANT

EXCLUSIVE ANCHORING SOLUTIONS

## STABILITY IN ANY ENVIRONMENT

When it comes to creating a solid foundation for your house, concrete spread footings and strip footings can't compete with helical piles' technological superiority and ease of installation!

GoliathTech screw piles are the industry's preferred supports, particularly in soft or unstable soil conditions and in areas prone to flooding and bogginess.

Our helical piles reach deep into stable soil to support your house, ensuring that the structure will remain secure over time while drastically reducing the risk of wall cracking. GoliathTech has a solution for any soil or environmental condition to support even the heaviest of loads.

Compared to concrete, our helical pile support system will save you thousands of dollars!

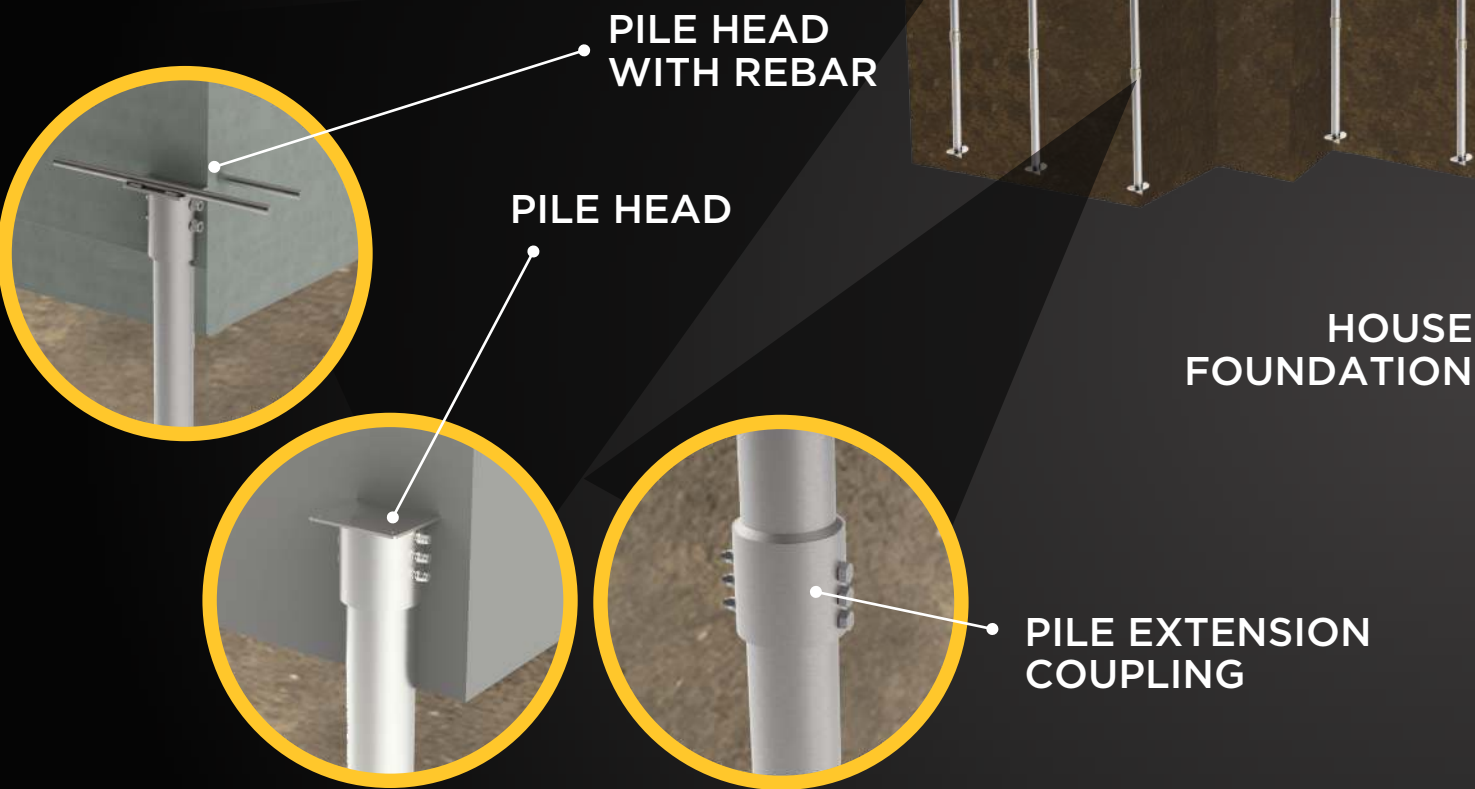

## INSTALLATION IN HOURS USING SMALL EQUIPMENT

✓ NO CONCRETE DELAYS OR DRY TIME

✓ NO MESS

✓ NO WEATHER DELAYS

✓ NO SOIL DISPLACEMENT OR REMOVAL

✓ REMOVABLE AND REUSABLE

## QUALITY ENGINEERING

- 1 SPECIAL PILE HEAD WITH REBAR
- 2 EXTENSION BOLTS AND MOUNTING BOLTS FEATURE HIGH SHEAR CAPACITY
- 3 REINFORCED JOINTS AND CONNECTIONS SECURED WITH SUPERIOR GRADE 5 BOLTS
- 4 GALVANIZING PROCESS PROTECTS STEEL AGAINST CORROSION

## PRECISE INSTALLATION ACCORDING TO ONSITE SOIL QUALITY IN 3 STEPS

### STEP 1. EVALUATE

Trained installer evaluates soil to determine its unique composition and assesses subsurface variability.

### STEP 2. GAUGE DEPTH

Our proprietary calibrated equipment's torque-reading pressure gauges determine the exact tension and compression values required to reach stable soil.

### STEP 3. INSTALL

GoliathTech helical piles specifically engineered for home foundation projects are installed deep into solid earth. These piles are height-adjustable to reach optimum soil.

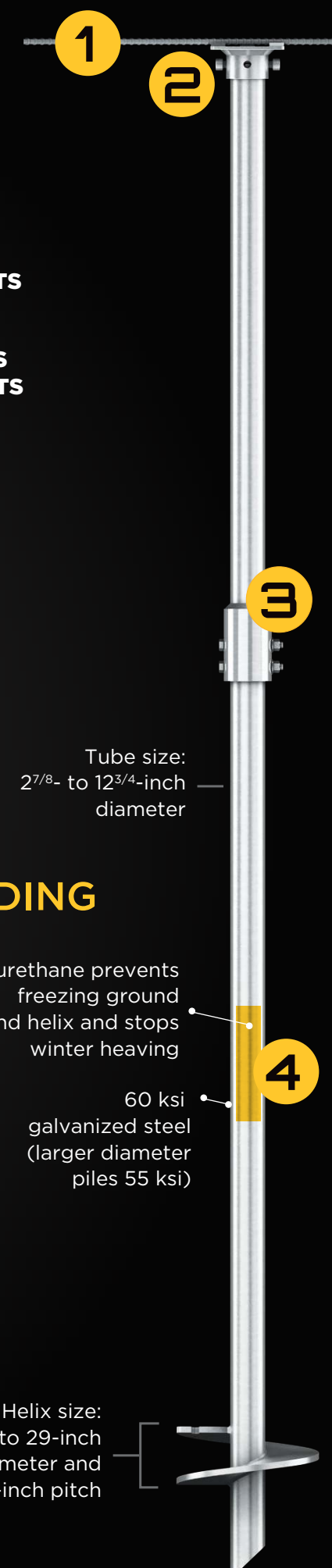

# WE ARE GOLIATHTECH

## THE PILLARS OF YOUR PROJECTS



### GOLIATHTECH'S INSTALLATION PROMISE

Our network of certified installers put their vast experience to work to guarantee optimal anchoring of each pile.

Because the quality of an installation is as important as the quality of the piles, all GoliathTech installers have received training at our factory and are certified technicians on the installation of our products.

Installers use mini excavators equipped with our proprietary calibrated torque-reading equipment, which allows them to determine the exact tension and compression values on each site. Their expertise ensures that the screw piles and the supported structure are built to last.

**BACKED BY THE GOLIATHTECH  
PROMISE, GUARANTEED!**

## QUITE SIMPLY SUPERIOR.

For more information on our products  
or to find a certified GoliathTech  
installer, please contact us:

**TOLL FREE: 1.855.743.4777**  
**INFO@GOLIATHTECHPILES.COM**

**WWW.GOLIATHTECHPILES.COM**



**CCMC**

**ACQ**

**CA**